

1044846



PATENT SPECIFICATION

DRAWINGS ATTACHED

1044846

Inventor: ALEXANDER JOHN CHERNEY

Date of Application and filing Complete Specification: March 10, 1965.

No. 10131/65.

Complete Specification Published: Oct. 5, 1966.

© Crown Copyright 1966.

Index at acceptance:—E1 K2B

Int. Cl.:—E 04 c 3/08

COMPLETE SPECIFICATION

Improvements in or relating to Lattice Building Elements

5 We, ALLOC LIMITED, a Body Corporate organised under the Laws of Great Britain, of 53, Shakespeare Road, London, N.W.7, do hereby declare the invention for which we pray that a patent may be granted to us and the method by which it is to be performed to be particularly described in and by the following statement:—

10 This invention relates to building elements, its object being to provide an improved construction of reinforcing element for use in the production of reinforced concrete beams or girders of inverted T-section.

15 According to the present invention a reinforcing element for a concrete beam or girder comprises an upper runner, an intermediate lattice constituted by a helix made of stiff wire and of triangular cross section, said helix being engaged by its apices with the upper runner, the two lower corners of the helix being formed as loops through which parallel rods are engaged.

20 In a preferred embodiment, the upper runner includes an inverted channel of U-section, the apices of the helix being inserted into and locked in the channel, e.g. by the formation of indentations in the wall of the channel. In a convenient arrangement, the apices of the helix are formed as radiused bends, the indentations being in the form of a tenon or crimp and the radiused bends being disposed between the tenon or crimp and the base of the channel. The upper runner may be formed as a cold-rolled or pressed piece of strip steel.

25 For engagement of the lower corners of the helix with the two rods, said lower corners may each be formed as a complete loop through which the respective rod is passed.

30 In the preferred embodiment, the base of each triangular turn of the helix is disposed normal to the vertical, longitudinal central plane of the element, the other two sides being directed at an angle of inclination along the element.

35 The wire helix may conveniently be formed

by machine from conventional mild steel reinforcing wire.

The reinforcing element may be of indefinite length, and preferably has the free ends of the wire secured to the upper runner. 50

Such a reinforcing element may be used in the production of a simple beam by providing a rectilinear cladding of concrete about the lower part of the triangular helix and the two rods. Where it is desired to form a girder of inverted T-section, a second cladding of concrete is provided about the upper part of the helix and the upper runner. 55

In order that the nature of the invention may be readily ascertained, an embodiment of reinforcing element and a concrete beam or girder utilising said element are hereinafter particularly described by way of non-limiting example with reference to the figures of the accompanying drawing, wherein:— 60

Fig. 1 is a perspective view of the reinforcing element, which may be of indefinite length; 65

Fig. 2 is a vertical section through a beam formed by cladding of the lower portion of such an element with concrete. 70

In the construction illustrated the reinforcing element comprises an upper runner 1 made of steel strip which is cold-rolled so as to provide therein a relatively deep central channel 2 of inverted U-section, plus a pair of flanges 3 each with an inturned edge 4 of comparatively small radius. 75

An intermediate lattice for the element is constituted by a length of mild steel reinforcement wire 5 of comparatively small gauge, which is bent by machine into a helix of triangular cross section. Commencing at the portion 6 a radiused bend of the wire helix is engaged in the channel 2 of the upper runner, then passes downwardly at 7 to form a closed loop 8 at the lower end, then transversely and normal to the vertical longitudinal plane, as at 9, to form another closed loop at 10, and then upwardly and forwardly at an inclination along the element to be engaged again in the 80 85 90

channel 2 of the upper runner, this formation being repeated along the entire length of the element, which may be of indefinite length.

5 The radiused bends of wire which are engaged in the channel 2 of the upper runner are locked therein by the formation, after insertion of the bend into the channel, of indentations or tenons 12 in the side wall of the channel. The bend of wire accordingly
10 becomes engaged between the base of the channel and the indentation 12.

15 As the wire is pre-formed into its triangular tubular shape, all of the loops 8 and all of the loops 10 are respectively in alignment with each other. To form a lower runner for the element, two steel reinforcement rods 13 are slid lengthwise through the respective series of loops, to result in the formation shown in fig. 1.

20 In practice, the wire helix could be supplied to the site having its turn relatively closely spaced, the individual turns, i.e. the portions 11, being pulled apart manually at the time of use, so as to obtain a desired spacing between the turns.

25 The free ends of the wire would be secured to the upper runner in any convenient manner, e.g. by formation of a complete loop about an indentation 12, or by welding to the upper runner.

30 The element of fig. 1 is then provided at its lower part with a rectilinear cladding 14 of concrete, as illustrated in fig. 2. In the form illustrated, the element may act as, for example, a flooring or roofing span beam, the un-clad portions above the concrete acting as a girder for reinforcing the beam against sagging.

35 If desired, the upper portion could also be incorporated in a further concrete cladding 15, thereby providing a reinforced concrete beam of inverted T-section.

WHAT WE CLAIM IS:—

45 1. A reinforcing element for a concrete beam or girder comprising an upper runner, an intermediate lattice constituted by a helix made of stiff wire and of triangular cross section, said helix being engaged by its apices with the upper runner, the two lower corners of the helix being formed as loops through which
50 parallel rods are engaged.

2. A reinforcing element for a concrete

beam, as claimed in claim 1, wherein the upper runner includes an inverted channel of U-section, the apices of the helix being inserted into and locked in said channel. 55

3. A reinforcing element for a concrete beam, as claimed in claim 2, wherein the apices of the helix are locked in the channel of the upper runner by the formation of indentations
60 in the wall of the channel.

4. A reinforcing element for a concrete beam, as claimed in claim 3, wherein the apices of the helix are formed as radiused bends, and wherein the indentations are formed as a
65 tenon or crimp, the radiused bend being disposed between the tenon or crimp and the base of the channel.

5. A reinforcing element for a concrete beam, as claimed in any one of the preceding claims, wherein the base of each triangular
70 turn of the helix is normal to the vertical longitudinal central plane of the element, the other two sides being disposed at an angle of inclination to the said plane. 75

6. A reinforcing element for a concrete beam, as claimed in any one of the preceding claims, wherein the free ends of the wire forming the helix are secured to the upper runner.

7. A reinforced concrete beam comprising a
80 reinforcing element as set forth in any one of the preceding claims, and a rectilinear cladding of concrete about the lower part of the triangular helix and the two rods.

8. A reinforced concrete beam of inverted
85 T-section comprising a reinforcing element as set forth in any one of claims 1 to 6, a first cladding of concrete about the lower part of the triangular helix and the two rods, and a second cladding of concrete about the upper
90 part of the helix and the upper runner.

9. A reinforcing element for a concrete beam, as particularly described herein with reference to fig. 1 of the accompanying drawings. 95

10. A reinforced concrete beam as particularly described herein with reference to fig. 2 of the accompanying drawing.

For the Applicants:

CHATWIN & COMPANY,
Chartered Patent Agents,
253, Gray's Inn Road,
London, W.C.1.

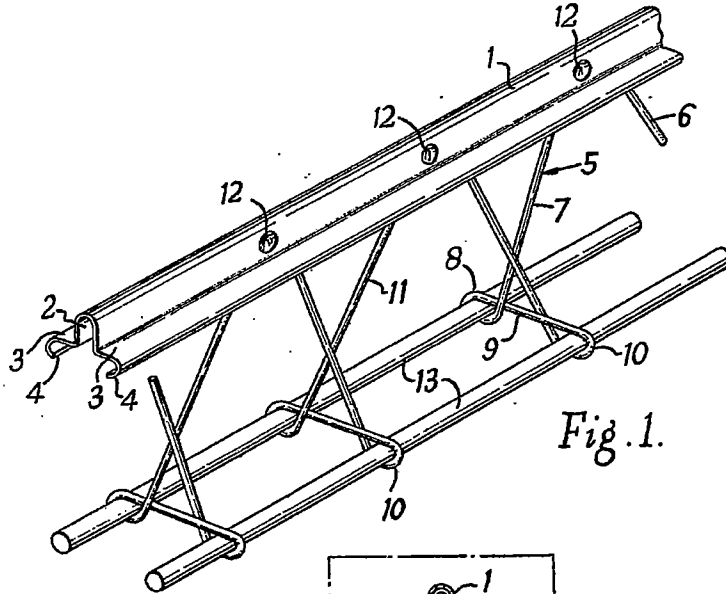

Fig. 1.

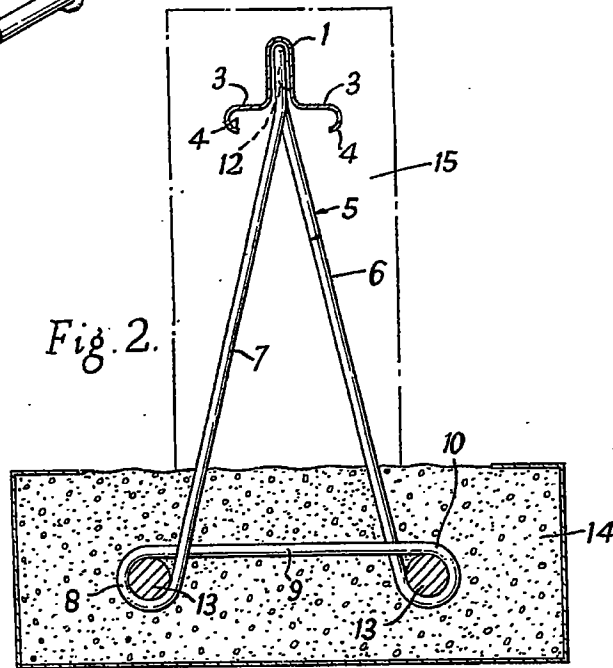

Fig. 2.